

WIRING DIAGRAM

STILETTO

Prior to Chassis Number B.30200001

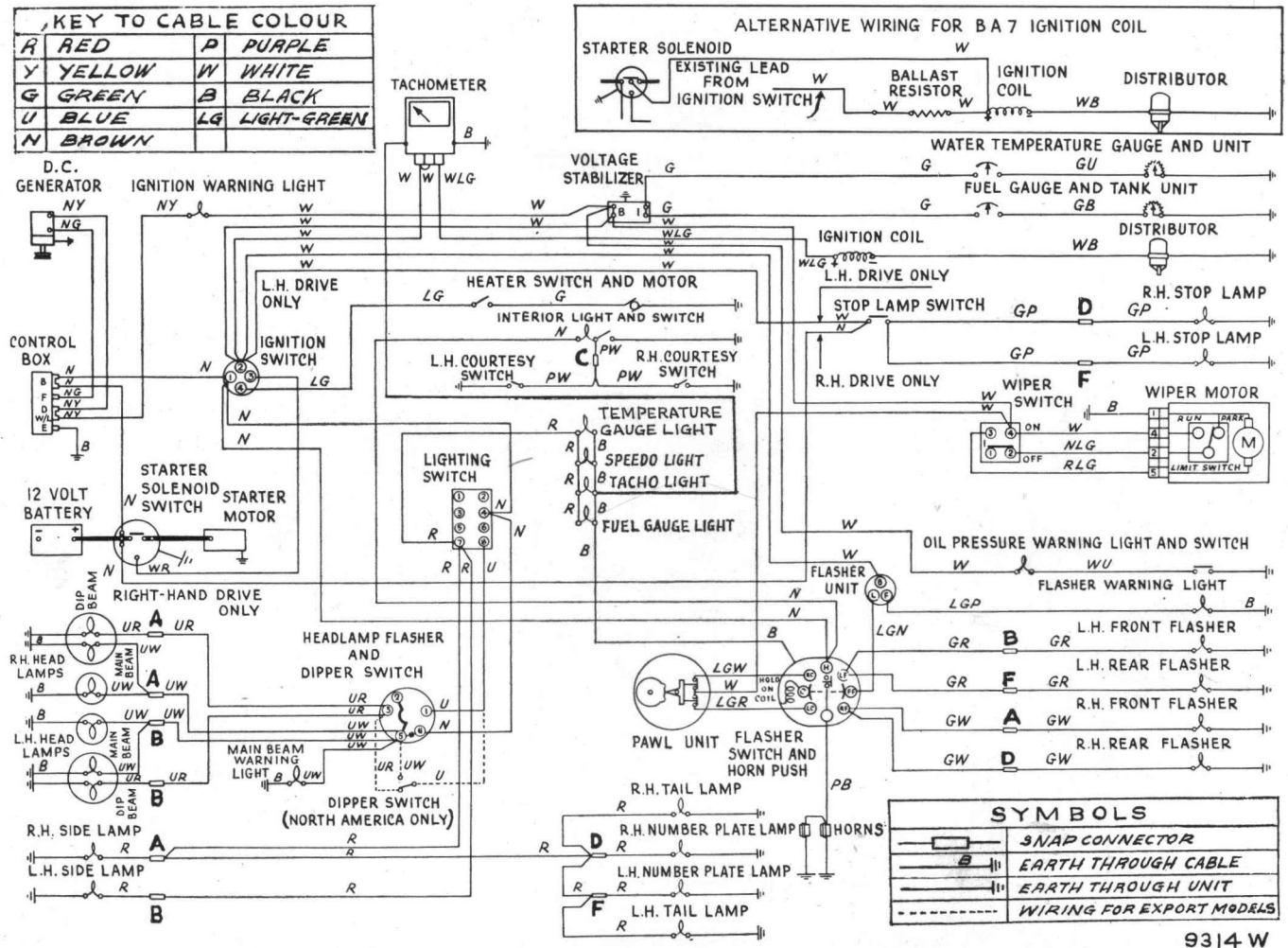

SNAP CONNECTORS LOCATIONS

- A —On right-hand front wing valance beneath glass fibre moulding.
- B —On left-hand front wing valance beneath glass fibre moulding.
- C —Below facia at extreme right-hand side.
- D —In engine compartment at right-hand side.
- E —Central in engine compartment lid.
- F —In engine compartment at left-hand side.

COMBINED HEADLAMP FLASHER AND DIPPER SWITCH IS REPLACED BY A SINGLE DIPPER SWITCH FOR NORTH AMERICA EXPORT WITH CABLES UR AND UW JOINED BY AN IN-LINE CONNECTOR. CONNECTIONS TO TERMINALS 3 AND 5 ON THE HEADLAMP FLASH-AND-DIP SWITCH ARE REVERSED FOR ALL LEFT-HAND-DRIVE EXPORT EXCEPT NORTH AMERICA AND FINLAND, AND FOOT DIP-LEAD "N" FROM LIGHTING SWITCH TERMINAL 4 TO HEADLAMP FLASH SWITCH TERMINAL 6 DELETED.