

WIRING DIAGRAM

IMP CALIFORNIAN

KEY TO CABLE COLOURS			
R	RED	P	PURPLE
W	WHITE	B	BLACK
Y	YELLOW	U	BLUE
N	BROWN	LG	LIGHT GREEN
G	GREEN		

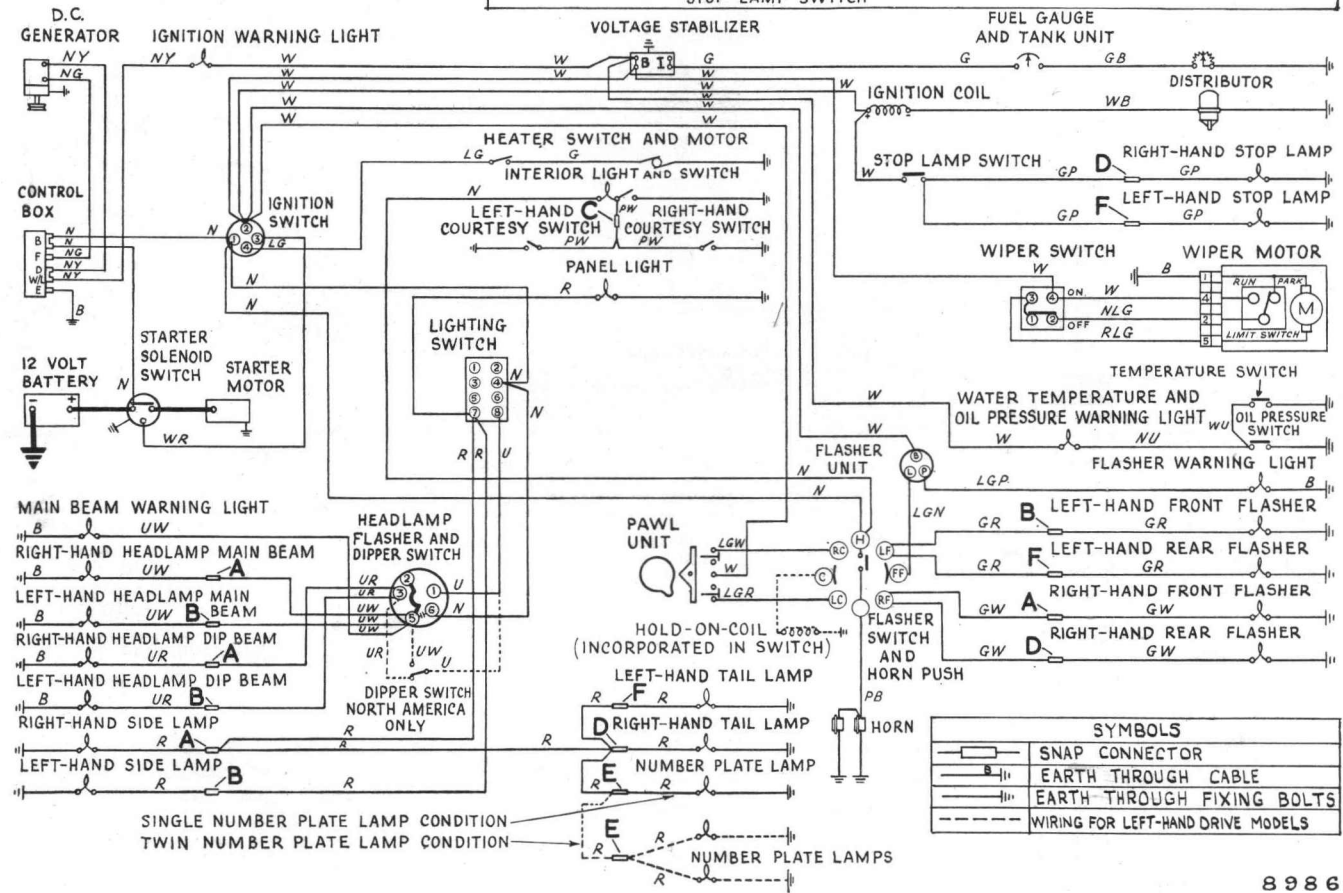
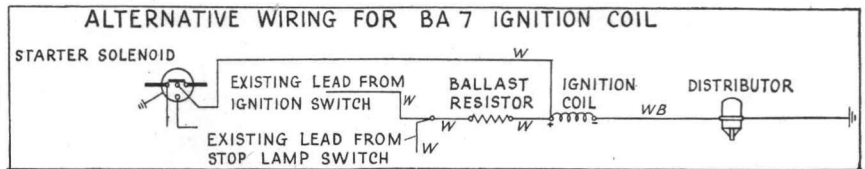

SYMBOLS	
	SNAP CONNECTOR
	EARTH THROUGH CABLE
	EARTH THROUGH FIXING BOLTS
	WIRING FOR LEFT-HAND DRIVE MODELS

8986

SNAP CONNECTORS LOCATIONS

- A —On right-hand front wing valance beneath glass fibre moulding
- B —On left-hand front wing valance beneath glass fibre moulding.
- C —Above parcel shelf on extreme right-hand side.
- D —In engine compartment at right-hand side.
- E —Central in engine compartment lid.
- F —In engine compartment at left-hand side.

COMBINED HEADLAMP FLASHER AND DIPPER SWITCH IS REPLACED BY A SINGLE DIPPER SWITCH FOR NORTH AMERICA EXPORT WITH CABLES UR AND UW JOINED BY AN IN-LINE CONNECTOR. CONNECTIONS TO TERMINALS 3 AND 5 ON THE HEADLAMP FLASH-AND-DIP SWITCH ARE REVERSED FOR ALL LEFT-HAND-DRIVE EXPORT EXCEPT NORTH AMERICA AND FINLAND, AND FOOT DIP-LEAD "N" FROM LIGHTING SWITCH TERMINAL 4 TO HEADLAMP FLASH SWITCH TERMINAL 6 DELETED.