

WIRING DIAGRAM

CHAMOIS Mk I

| COLOUR CHART | |
|--------------|-------------|
| R | RED |
| W | WHITE |
| Y | YELLOW |
| N | BROWN |
| G | GREEN |
| U | BLUE |
| P | PURPLE |
| B | BLACK |
| LG | LIGHT GREEN |

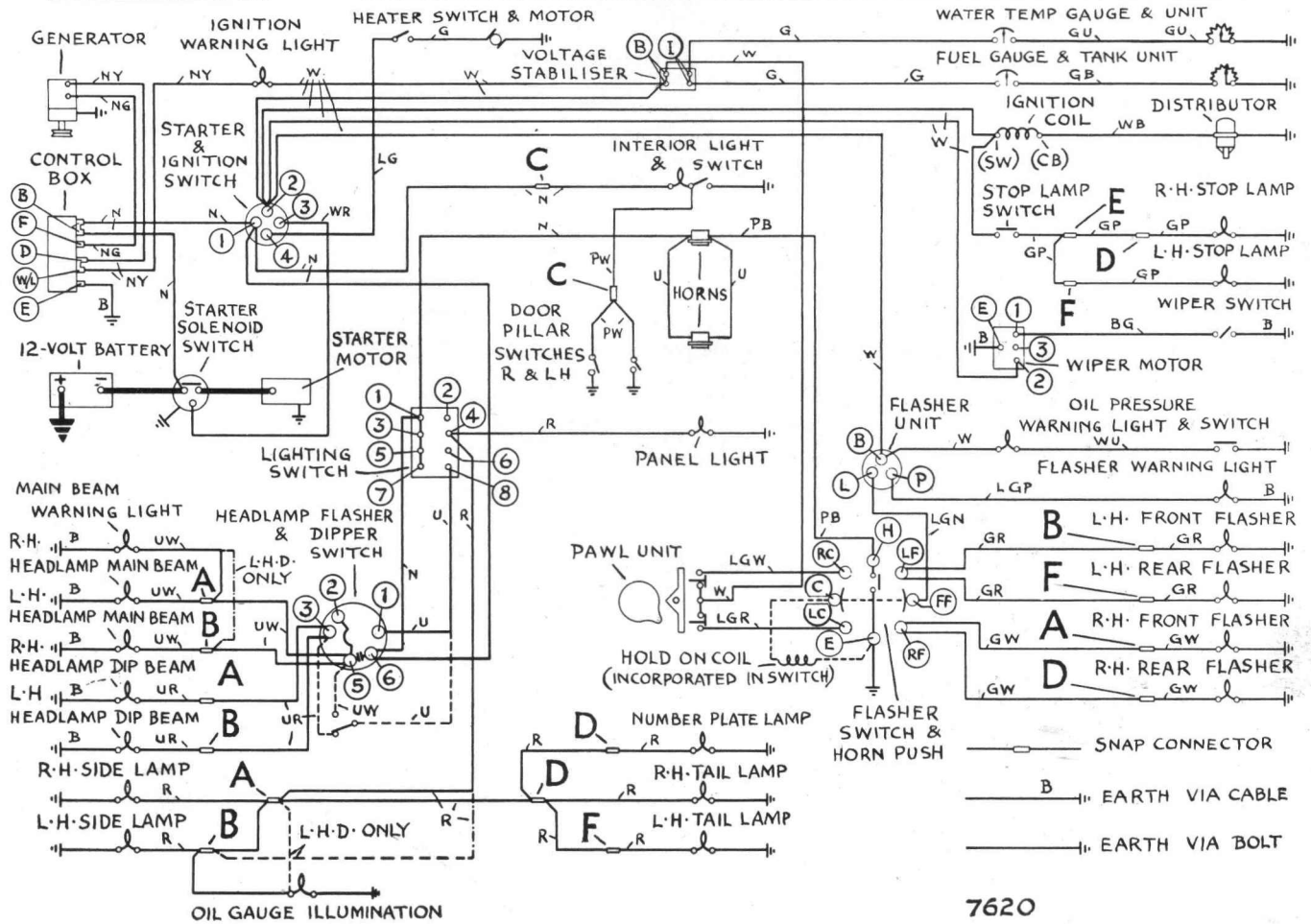
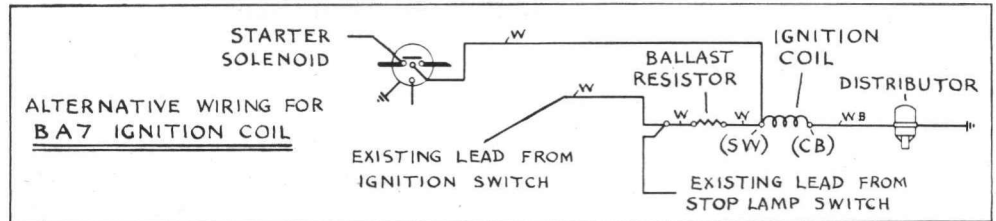

COMBINED BINNACLE-MOUNTED HEADLAMP FLASHER & DIPPER SWITCH IS REPLACED BY A FLOOR-MOUNTED DIPPER SWITCH FOR NORTH AMERICA EXPORT. IN THIS INSTANCE, THE UW AND UR CABLES FROM THE HEADLAMPS WHICH ARE NORMALLY CONNECTED TO THE HEADLAMP FLASHER AND DIPPING SWITCH, ARE JOINED BY IN-LINE CONNECTORS AND THE N LEADS WHICH CONNECT AT TERMINAL SIX OF THIS SAME SWITCH, ARE DELETED.

For snap connector locations refer to page 40

7620